

Denman Conservancy Association

Memorial Bench Policy

Adopted by the DCA Board: April 21, 2014

- 1) The DCA Board will consider on a case-by-case basis all requests to donate and install a memorial bench on DCA lands. The Board will consider the memorialized person's connection with Denman Island as a major factor in the decision.
- 2) The proposed site of a memorial bench must comply with DCA's Management Plan for the land.
- 3) Although the proposed design and installation should meet DCA criteria (see Addendum #1), other proposed designs will be considered and may be approved by the Board.
- 4) The purchase and installation of the bench is the responsibility of the donor.
- 5) Upon the acceptance by DCA of a donated memorial bench it becomes the sole property of DCA.
- 6) A tax receipt may be provided for a donated bench if invoices for the building and installation of the bench are provided to the DCA.
- 7) DCA undertakes to maintain a donated bench for as long as it remains structurally sound (currently expected to be in excess of 10 years). The donor may take on maintaining the bench, by agreement with the Board, or may provide a donation for the estimated cost of the maintenance of the bench. (See addendum #2). This donation may be used by the DCA for any of its programs.
- 8) DCA will not be responsible for replacing a bench or plaque that is stolen, destroyed or damaged beyond practical repair. The DCA will make reasonable efforts to contact the donor if the bench needs to be removed.
- 9) All aspects of the memorial bench program will be at the discretion of the Board.

DCA Memorial Bench Policy, Addenda

Addendum #1. Design Criteria:

Size: See Diagram -- P. Karsten drawing, attached.

Approximately: 48" – 60" long x 40 " high at back, seat height 17".

Materials: Cedar (Western Red or Yellow);

Fasteners: exterior screws or bolts, filling holes where needed.

Small concrete pads poured in place, with braces to attach minimum of 2 legs.

Recommended finish: Lifetime® wood finish made by Valhalco.

Design: See "Basic Design" drawing by Peter Karsten, custom made.

Plaque optional, but if included will be made of bronze and fastened with epoxy.

Different designs, to be considered by the Board, should take into account: custom-made, not commercial; natural, long lasting 'local' species wood; sturdy design and construction; fastened to ground with minimum impact, non-toxic finish.

Addendum #2. Donation

The estimated cost for bench maintenance:

As of 2014, we estimate \$400 should be adequate to: check the condition of the bench annually or more often and to make any necessary repairs to ensure its structural soundness. Washing with water occasionally suggested. Reapplication of a finish may be included if necessary. (Lifetime® finish claims that only one application is needed.) The work could be done by the land manager, someone else hired for the task, or the property management committee could undertake this responsibility, to save money for other DCA uses. Maintenance should continue for about ten years, more or less, at the discretion of the Board.

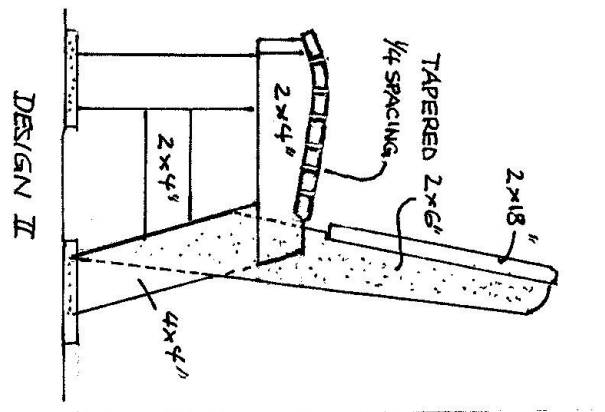
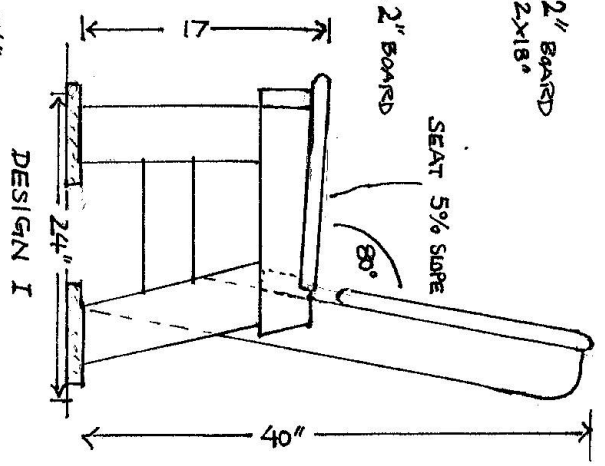
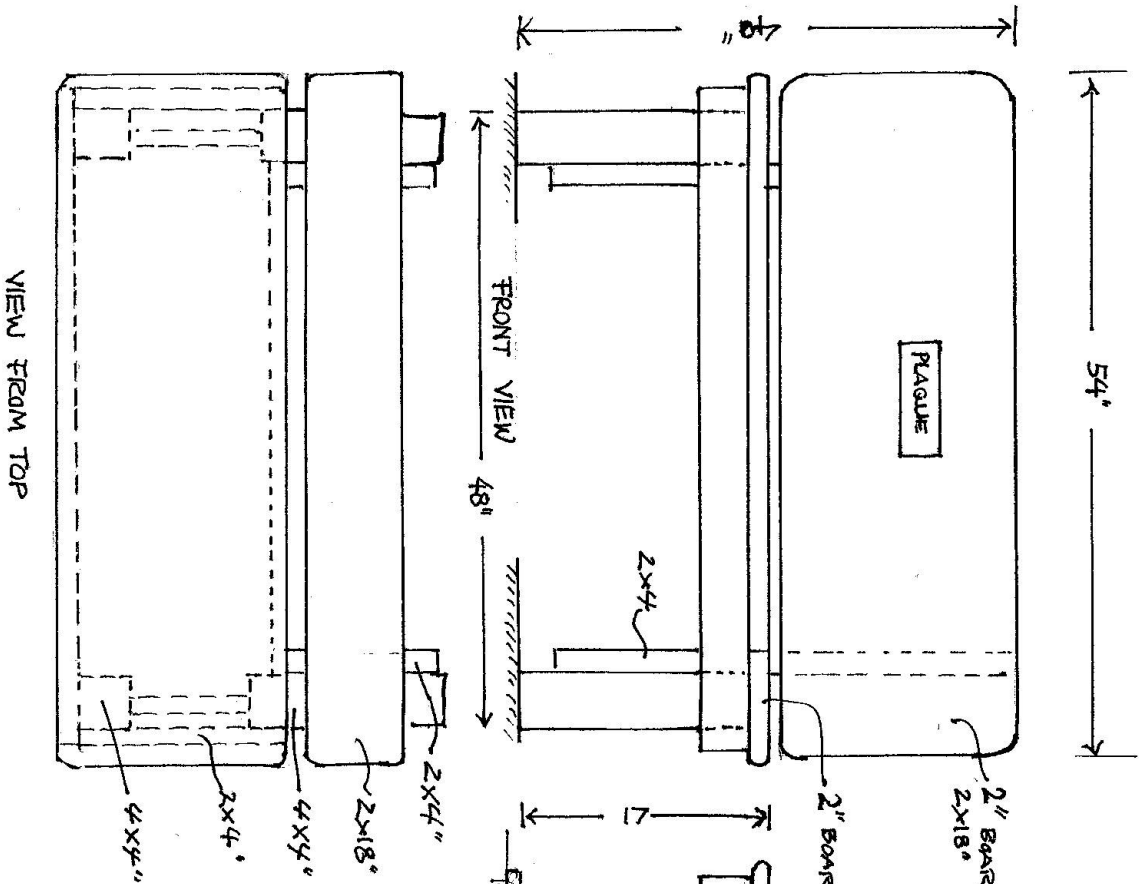

MEMORIAL BENCH
BASIC DESIGN
 YELLOW CEDAR OR
 WESTERN RED CEDAR



APPROX. WEIGHT 60 lbs

